



Technical Manual

WorldWEIGH

Portion Washdown Scales

V1.06-1.10

CONTENTS

1. PRECAUTIONS	- 3 -
2. INTRODUCTION	- 4 -
3. SPECIFICATIONS	- 5 -
4. INSTALLATION	- 6 -
5. PARTS DESCRIPTION	- 8 -
6. OPERATION	- 10 -
1. Power ON/OFF	- 10 -
2. Zero	- 10 -
3. Tare	- 10 -
4. Back light	- 10 -
5. Weighing Units	- 11 -
6. Auto power off setting	- 11 -
7. PARAMETERS	- 12 -
8. CALIBRATION	- 14 -
9. ERROR CODE	- 15 -

1. PRECAUTIONS



CAUTION

- **Permit only qualified persons to service the instrument**
- **Before connecting or disconnecting any components, unplug the power.**
- **Failure to observe these precautions bodily harm or damage to or destruction of the equipment.**

- Avoid leaving the scale in direct sunlight, which may cause discoloration.
- Avoid overloading, this could cause damage to the scale.
- If the scale is not used for a long period of time, remove all batteries from the battery compartment to avoid leakage.
- Avoid stacking materials on the scale when not in use.
- Avoid unsuitable tables. The tables and floor must be rigid and isolated from vibration. Do not place near vibrating machinery.
- Avoid unstable power sources. Do not use near high voltage machines such as welding equipment or large motors.
- Do not mix battery brands. Replace all the batteries at the same time (Dry Cell).
- Only use original World Weigh WD adaptor, others could cause damage to the scale.
- When the scale is used with an adaptor it is not in conformance with IP-65 protection.

IP 6 5

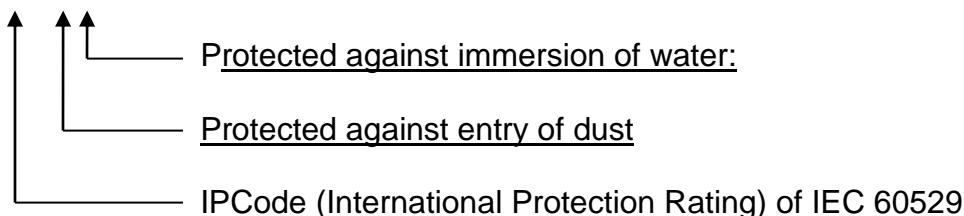

2. INTRODUCTION

- The WorldWeigh WD series weighing scales are fully waterproof scales.
- It is suitable for sanitary applications and general weighing.
- IP65 waterproof technology
- Stainless steel housing.
- Super low power consumption.
- Built in rechargeable battery.
- Large 25mm (0.98inch) digits LCD with white LED back light display.
- Optional 20mm (0.78inch) digits LCD rear display

3. SPECIFICATIONS

SPECIFICATION

MODEL	S29-6	S29-12	S29-30	S29-60
Capacity	6lb / 3kg / 96oz	12lb / 6kg / 192oz	30lb / 12kg / 480oz	60lb / 25kg / 960oz
Readability	0.001lb/0.005kg/ 0.02oz	0.002lb/0.001kg/0.05oz	0.005lb/0.002kg / 0.1oz	0.01lb / 0.005kg / 0.2oz
Max. Divisions	6000e			
Weighing Units	kg/g/lb./oz/lb. Oz			
Display	0.98inch /25mm digits LCD Display with white LED back Light			
Platter size	9 x 7.5inch / 230 x 190mm			
Housing	Stainless Steel			
Operation Temperature	14°F - 104°F / -10°C - + 40°C			
Power	AC Adaptor 12V/500mA, Rechargeable Battery 6V/3.2Ah			
Battery life	Approx.70 Hours LCD (no backlight)			
Keypad	3 mechanical keys			
Dimensions (inch/mm)	9.6 (W) x 11.8 (D) x 5.0 (H) / 242.93 (W) x 299.7 (D) x 126.7 (H)			
Gross weight	9.3lb (4.2kg)			

DIMENSION (mm)

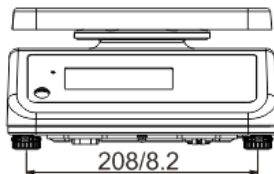
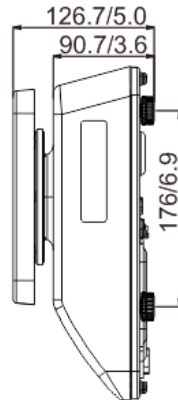
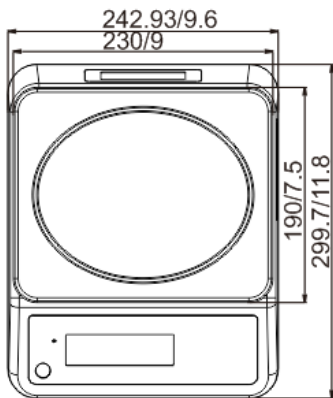

4. INSTALLATION

Unpacking

Carefully take the balance out of its package, make it sure it's not damaged, and all accessories are included.

- Remove the Indicator from the carton.
- Remove the protective covering. Store the packaging for use if you need to transport the scale later.
- Inspect the scale for any damage.
- Make sure all components are included

Accessories,

1. Balance
2. Adaptor
3. Pan
4. Product manual

Level Adjusting

Place the scale on a table.

Check the water mark. If the bubble is not centered, adjust the leveling feet until reach center. Always check the level when you change the scales location.

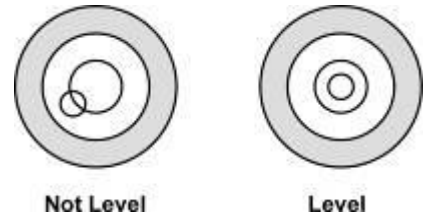

Charging Battery



- To charge the battery, insert the adaptor pin into the jack located under the scale. The adaptor simply plugs into the receptacle. The scale does not need to be turned on to charge.
- The battery should be charged for 12 hours to fully charge.
- There is an LED on the left side of the display that shows the status of the battery charging. When the scale is plugged in, the battery will charge. If the LED is green, the battery has a full charge. If it LED is red, the battery is nearly discharged and if yellow, the battery is being charged.
- Do not use any power adaptor other than the one supplied with the scale.
- Verify that the AC power socket outlet is properly protected.

Note: Please charge the battery before using the scale for the first time

 **CAUTION**

Below the scale there is a breathable knob. Its default setting is for weighing. If you want to wash the scale tighten the knob, after washing release the knob for weighing.



Installation

- Place the scale on the table.
- Connect the adaptor pin into the indicator adaptor jack. Adaptor jack is located, on the underside of the scale.
- Plug the adaptor into the receptacle. Equipment must be installed near an easily accessible outlet with a protective ground/ earth circuit.
- Press the On/Off key. If you want to turn off, press the key again.
- Display will show the version number and will start a self-check test.
- After the self-check, the display will go to normal weighing mode.
- A warm-up time of 15 minutes stabilizes the measured values.
- Recommend using certified weights for calibration see details in parameter.

The scale is now ready for use.

5. PARTS DESCRIPTION

Rechargeable Battery



Adaptor jack

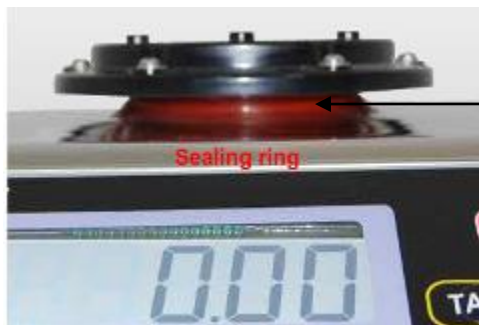

Sealing Ring

Breathable Knob



Breathable Knob

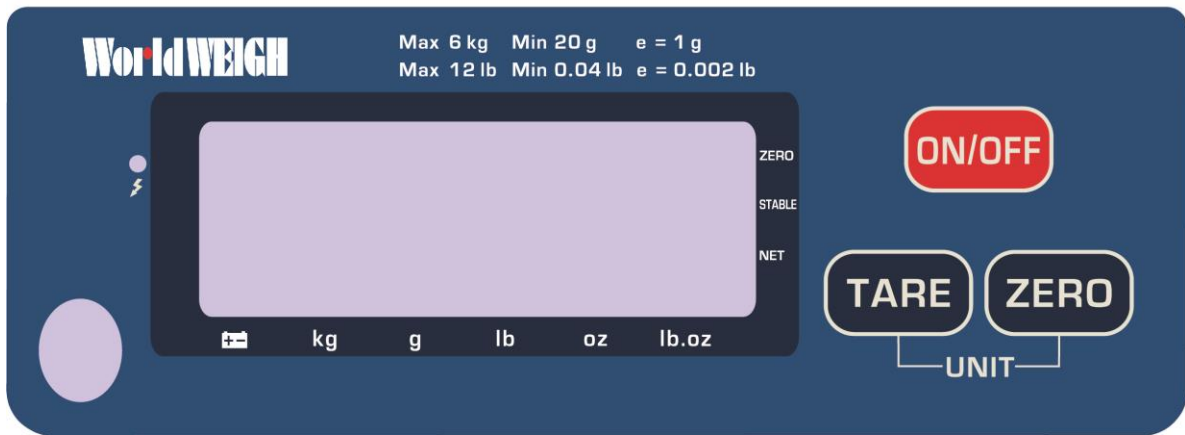

Key Board



Weight Display

Zero	Zeroing Display
Stable	Stable Display
Net	Net Weight Display
	Low Battery
kg/g/lb/oz/lb.oz	Current Weighing Mode

Keys

-  : Turns the scale power On / Off
-  : Subtracts weight of container
-  : Sets display to Zero

6. OPERATION

Initial Start-up

Warm-up time of 15 minutes stabilizes the measured values after switching on.

1. Power ON/OFF

Switch on the scale by pressing **ON OFF**. The display is switched on and the self test is started.

If you want to switch off press the key again.

2. Zero

Pressing the **ZERO** key will ensure that the weighing starts at zero.

3. Tare

The weight of any container can be removed by pressing the **TARE** button.

- Load weight on the pan.
- Press **TARE** key. Zero is displayed, and tare is subtracted.
- Remove the container from the platform and the tare weight is displayed. It will show a minus value.
- Press **TARE** key again and zero is displayed, tare weight is cleared.

4. Back light

Press the **ZERO** key for three seconds, the display will show "BK-AU", Press the **TARE** to select back light AU/OFF/ON, then press the **ZERO** key to confirm.

Display	Description
Bk AU	Backlight will be turned on, when weight is applied or when display is not at zero.
Bk oF	Backlight function will be turned off.
Bk on	Backlight will be always turned on.

5. Weighing Units

Press the **TARE** and **ZERO** keys together to change the weighing mode. The weighing units can be changed to kg/g/lb./oz/lb. Oz

6. Auto power off setting

To change the auto power off setting to turn the scale off when not in use, scale will turn off after the setting time. Enter the setup menu by powering up and holding the tare button then press tare until F5 off is displayed. Press zero to enter then

press **TARE** key to select the option, press **ZERO** key to confirm

F5 off	Off	To set auto off function turn off, for scale always on
	Of 3	Set to turn off three minutes later
	Of 5	Set to turn off five minutes later
	Of 15	Set to turn off 15 minutes later

7. PARAMETERS

Enter the Menu

- Turn on the scale. Press **TARE** during that start up until display will be shown

F1Cal

Enter the Selected Menu

- Press **ZERO** to confirm what is shown on the display.

Select the Menu

- Press **TARE** to scroll through the menu block and zero to enter.

Note: If you want to access parameters F1 CAL; F2 RES; F3 CAP;F6 GRA; , press the CAL switch in the battery compartment. Remove the battery housing and battery to locate the CAL switch.

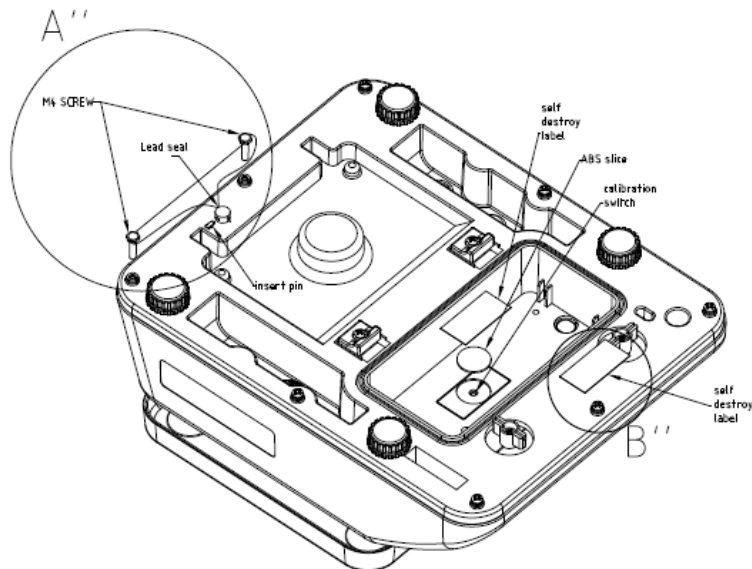

Menu	Description	
F1 cal	kg	Calibration in kg mode
	lb	Calibration in lb mode

F2 res	3000	Set Resolution
	6000	
	dual	
F3 cap	3kg (6lb)	Set Scale Capacity
	6kg (12lb)	
	12kg (30lb)	
	25kg (60lb)	
F4 inp	Internal Counts	
F5 Off	Set scale for auto turn off.	
	3 min	Auto off after three minutes.
	5 min	Auto off after five minutes.
	15 min	Auto off after 15 minutes.
	off	Auto off function disable
F6 gra	xxxx	Set local gravity
F7 spd	7.5	Set AD speed
	15	
	30	
	60	
Back	Back to weighing mode	

8. CALIBRATION

1. Turn on the scale. Press and hold **TARE** key during start up until display shows. **F1 Cal**

Then press the calibration switch located below the battery

2. Press **ZERO** to confirm, the display will show **kg**
 - a. If calibrating in **kg**, continue step 3
 - b. If calibrating in **lb**, press the **TARE** key and **lb** will be shown on the display

Ensure that the platter is empty.

*Note: Press the **TARE** key to choose either "kg" or "lb".*

3. Press the **ZERO** to confirm and the display will show **unload**
4. Press **ZERO** the display will show the current calibration weight value **2 lb**
5. If needed press **TARE** to select the weight value.
6. Apply the weight to the platform. Wait for the indicator to stabilize then press the **ZERO** key to confirm. The display will show **PASS**.

7. The scale will restart.

If the display shows an error message or incorrect measurement, repeat the calibration again.

9. ERROR CODE

Error Message	Description	Solution
Err 4	Zero setting error	Zero setting range exceeded due to switching on. (4%max) Make sure platform is empty.
Err 5	Key board error	Check the keys and connecter.
Err 6	A/D value out of range	Make sure platform is empty and ensure that the pan is installed proper. Check the load cell connectors.
Err 9	Unstable Reading	Check for any air variation, vibration, RF noise or if the scale is touching anything. Check the load cell and connectors.
Err 17	Tare out of range	Remove the load and restart scale again.
--ol--	Over range	Remove the load. Re calibrate
Fai l h / fai l l	Calibration Error	Re calibrate
Ba lo / lo ba	Battery low	Re charge battery, check the voltages.

10. REPLACEMENT PART NUMBERS

Parts List

No	B-TEK Part #	Parts Name
1	899-300139	SS TOP PAN Part number 1
3	899-300140	Rubber1
4	899-300141	Rubber2
5	899-300142	Pan Support
14	899-300143	Front Display PCB
16	899-300170	WD-6lb Load Cell
16	899-300171	WD-12lb Load Cell
16	899-300172	WD-30lb Load Cell
22	899-300176	Battery
23	899-300145	Battery Box Cover
32	899-300173	WD-6LB OVERLAY
32	899-300174	WD-12LB OVERLAY
32	899-300175	WD-30LB OVERLAY
33	899-300147	Front Display Protection
43	899-300148	Seal Rubber 2
46	899-300149	Foot Fixer
47	899-300150	Foot



B-TEK Scales, LLC
1510 Metric Ave. S.W.
Canton, OH 44706
Tel: 330.471.8900
Fax: 330.471.8909
www.B-TEK.com