

# Hi - Impact / Coil



## Electro-Mechanical Hi-Impact / Coil Scale

### General Specifications

- Certificate of Conformance: NON-NTEP
- Type: Above ground or pit
- Scale Capacity: 20,000 - 120,000 lbs.
- Scale Height: 24" - 36" based on platform size and capacity
- Available Sizes: Custom - Built as specified
- Weighbridge Deck: I-beam structure with optional springs for shock loading
- Steel Preparation: Commercial blast cleaning SSPC-SP6
- Paint System: Cross-Linked two-part Epoxy - 2 to 4 mil primer base coat  
Two-part UV resistant Polyurethane - 2 to 4 mil top coat
- Mechanical Suspension: Lever system with ball bearing suspension

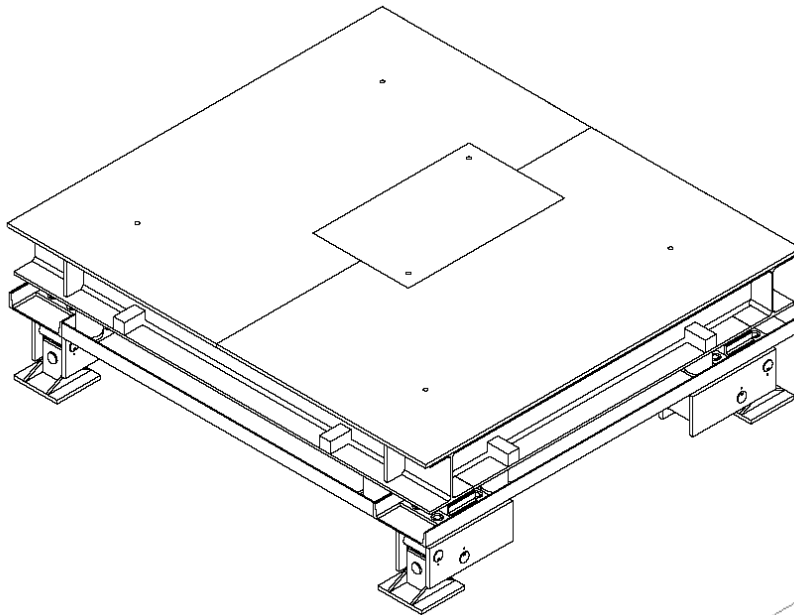

75K Capacity 96" x 108" Electro-Mechanical Hi-Impact Scale  
Ball Bearing Lever System  
Shown Outside of (Optional) Portability / Protective Frame

75K Capacity 96" x 108" Electro-Mechanical Hi-Impact Scale  
4-Way Checking Adjustments Show on Side of Frame  
Extra Directional Checking on Top of Deck and Frame

Shown Inside of (Optional) Portability / Protective Frame

